

UNIVERSITY OF MICHIGAN

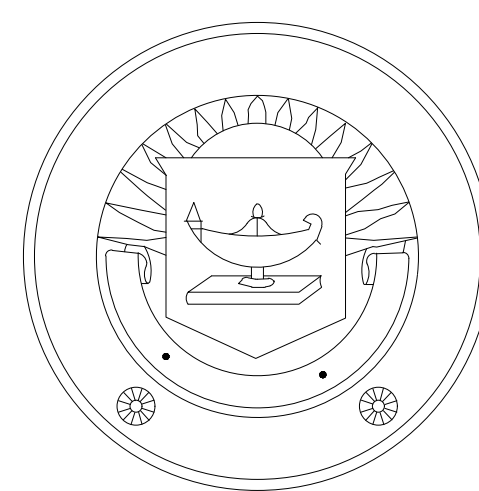

COLLEGE OF ENGINEERING

G.G. BROWN LABORATORY MECHANICAL ENGINEERING ADDITION

U of M Building # 407
2350 Hayward Street

ARCHITECT:

GENERAL CONTRACTOR:

GLAZING CONTRACTOR:

MATERIAL	ABBREVIATIONS
PLYWOOD	A/C = ACCESS CONTROLLED
BATT INSULATION	A.F.F. = ABOVE FINISHED FLOOR
GLAZED TILE	B.O.H. = BOTTOM OF HORIZONTAL
MARBLE	C = CENTER LINE
ACOUSTICAL CEILING	DIM. = DIMENSION
FINISHED WOOD	D.L.O. = DAYLIGHT OPENING
DIMENSION LUMBER	D.L. = DEAD LOAD (ANCHOR)
FACE BRICK	D.O. = DOOR OPENING
RIGID INSULATION	EL. = ELEVATION
CUT STONE	F.S. = FRAME SIZE
CONCRETE	F.F. = FINISH FLOOR
CONCRETE BLOCK	G.C. = GENERAL CONTRACTOR
STEEL IN SECTION	M.O. = MASONRY OPENING
CAULKING	M.L. = MULLION LENGTH
BACKER ROD	N.I.C. = NOT IN CONTRACT
	N.T.S. = NOT TO SCALE
	O.D. = OPENING DIMENSION
	O.F.D. = OVERALL FRAME DIMENSION
	REF. = REFERENCE
	R.O. = ROUGH OPENING
	T.O.STL. = TOP OF STEEL
	U.N.O. = UNLESS NOTED OTHERWISE
	V.I.F. = VERIFY IN FIELD
	OPP. = OPPOSITE
	SIM. = SIMILAR
	TYP. = TYPICAL
	W.P. = WORKING POINT

SYMBOLS	DESIGN CRITERIA
FINISH FLOOR LEVEL	WIND LOADS
ANCHOR LOCATION	CODE/STANDARD: _____
SPLICE LOCATION	WIND SPEED: _____
TEMPERED	IMPORTANCE FACTOR: _____
STEEL REINFORCEMENT	EXPOSURE CATEGORY: _____
NOTE:	MEAN ROOF HEIGHT: _____
	DESIGN PRESSURE (PSF) _____
	TYPICAL WALL: _____
	CORNER ZONES: _____
	SNOW LOAD: _____
	ALLOWABLE DEFLECTION
	L/ 175
	MAXIMUM: 3/4"

GENERAL NOTES

- SABCAD, INC WILL ASSUME NO RESPONSIBILITY FOR ERRORS RESULTING FROM THE USE OF THESE DRAWINGS BY OTHER TRADES.
- FINAL APPROVAL BY THE GENERAL CONTRACTOR CONSTITUTES ACCEPTANCE OF ALL DEVIATIONS TO THE CONTRACT DOCUMENTS MADE BY SABCAD, INC IN THESE DRAWINGS.
- THESE DRAWINGS REPRESENT SABCAD'S INTERPRETATION OF THE APPLICATION OF PRODUCTS TO THIS PROJECT IN FUNCTIONAL COMPLIANCE WITH THE ARCHITECT'S DRAWINGS AND SPECIFICATIONS. IT IS IMPORTANT THAT THIS INTERPRETATION BE REVIEWED DIMENSIONALLY AND FUNCTIONALLY WITH RESPECT TO ACTUAL ARCHITECT INTENT, INTERFACING CONDITIONS, MATERIALS AND JOB SITE CONDITIONS.
- ALL DIMENSIONS SHALL BE FIELD VERIFIED AND/OR APPROVED BY THE GENERAL CONTRACTOR PRIOR TO GLASS ORDERING AND FABRICATION.
- ALL GLASS AND FINISHED MATERIAL MUST BE PROTECTED DURING WELDING OPERATIONS, FIREPROOFING OR ANY OTHER PROCESS THAT MAY BE HARMFUL TO THE APPEARANCE OR PERFORMANCE OF THE PROJECT MATERIALS.
- THE ROUGH OPENINGS PROVIDED MUST BE SQUARE AND WITHIN SPECIFIED BUILDING TOLERANCES.
- PERIMETER FASTENERS AND SUBSTRATE MUST BE CAPABLE OF WITHSTANDING REACTION FORCES IMPOSED BY WIND AND/OR DEAD LOAD. SABCAD, INC WILL NOT BE LIABLE FOR INSUFFICIENT ANCHORING AND/OR SUBSTRATE.
- LAWS AND BUILDING AND SAFETY CODES GOVERNING THE DESIGN AND USE OF GLAZING ENTRANCE, WINDOW AND CURTAIN WALL PRODUCTS VARY WIDELY. SABCAD, INC DOES NOT CONTROL THE SELECTION OF PRODUCT CONFIGURATIONS, OPERATING HARDWARE OR GLAZING MATERIALS AND ASSUMES NO RESPONSIBILITY.

LIST OF DRAWINGS		
SHEET #	DESCRIPTION	SCALE
1.1	COVER SHEET	NTS
1.2	KEY PLAN	1/8" = 1'-0"
1.3	KEY PLAN	1/8" = 1'-0"
1.4	BREAK METAL LAYOUT	1/8" = 1'-0"
1.5	BREAK METAL SIZES	1/2" = 1'-0"
1.5A	BREAK METAL SIZES	1/2" = 1'-0"
1.6	DETAILS	FULL
2.1	ELEVATIONS	1/2" = 1'-0"
3.1	DETAILS	1 : 2
3.2	DETAILS	FULL
3.2A	DETAILS	FULL
3.3	DETAILS	FULL
3.4	DETAILS	FULL
3.4A	DETAILS	FULL
3.5	DETAILS	FULL
3.5A	DETAILS	FULL
3.6	DETAILS	FULL
3.7	DETAILS	1 : 2

GLASS SCHEDULE
GL-1 1" CLEAR LOW-E O.B. 1/4" CLEAR (T) SN-68 # 2 A.S. 1/2" CLEAR ANODIZED W/ARGON I.B. 1/4" CLEAR (T)
GL-2 1" SPANDREL O.B. 1/4" CLEAR (T) SN-68 # 2 A.S. 1/2" CLEAR ANODIZED W/ARGON I.B. 1/4" CLEAR (T)W / CUSTOM CERAMIC FRIT # 4

ALUMINUM FINISH
GL-1 EFCO TO MATCH PPG DURANAR UC57638XL "BRIGHT SILVER"

DISCLAIMER

THESE SHOP DRAWINGS ARE AN INTERPRETATION OF THE CONTRACT DOCUMENTS. IT SHALL BE THE RESPONSIBILITY OF THE GENERAL CONTRACTOR / CONSTRUCTION MANAGER AND THE ARCHITECT TO REVIEW THESE DRAWINGS FOR COMPLIANCE WITH THE DESIGN INTENT AND CONTRACT DOCUMENTS. WHEN THESE DRAWINGS ARE RETURNED WITH "APPROVED", "APPROVED AS NOTED", OR "REVIEWED" STAMPED ON THEM, IT SHALL CONSTITUTE THE GENERAL CONTRACTOR / CONSTRUCTION MANAGER AND THE ARCHITECT AGREEMENT THAT THE SHOP DRAWINGS DO COMPLY WITH THE DESIGN INTENT AND THE CONTRACT DOCUMENTS AS NOTED WITH IN. WHEN COPIES OF THESE SHOP DRAWINGS ARE GIVEN TO OTHER TRADES FOR COORDINATION PURPOSES, THOSE TRADES HAVE TO BE AWARE THAT ALL DIMENSIONS ON THE SHOP DRAWINGS ARE SUBJECT FOR FIELD VERIFICATION.

GENERAL NOTES	REVISIONS	PROJECT:	G.G. BROWN LABORATORY MECHANICAL ENGINEERING ADDITION	SABCAD, INC.	SHEET DESCRIPTION	SCALE: NTS
* ALL DIMENSIONS TO BE VERIFIED IN FIELD	FIRST ISSUE: 05/25/2012	PROJECT NO: 08143-3000		PROFESSIONAL DRAWINGS	COVER SHEET	SHEET NO. 1.1
* ALL ELEVATIONS ARE VIEWED FROM OUTSIDE OR FROM THE PULL SIDE OF THE DOOR	REVISION # 1 - DESIGN CONCEPT 07/16/2012	LAST UPDATE: 02/02/12		P.O BOX 336 CLAWSON, MI 48017 PH: (248) 635-9155 FAX: (248) 282-0595 www.sabcatidnc.com		
* ALL PARTS NO.(S) TO BE VERIFIED BY THE PURCHASING DEPARTMENT	REVISION # 2 - DESIGN CONCEPT / DIES 08/10/2012	ARCHITECT: Integrated Design Solutions			SABCAD JOB NO.12-25	
	REVISION # 3 - FINAL DESIGN 09/04/2012	G.C: DeMARIA BUILDING COMPANY				
	REVISION # 4 - CORRECTIONS FOR RECORD 10/29/2012					

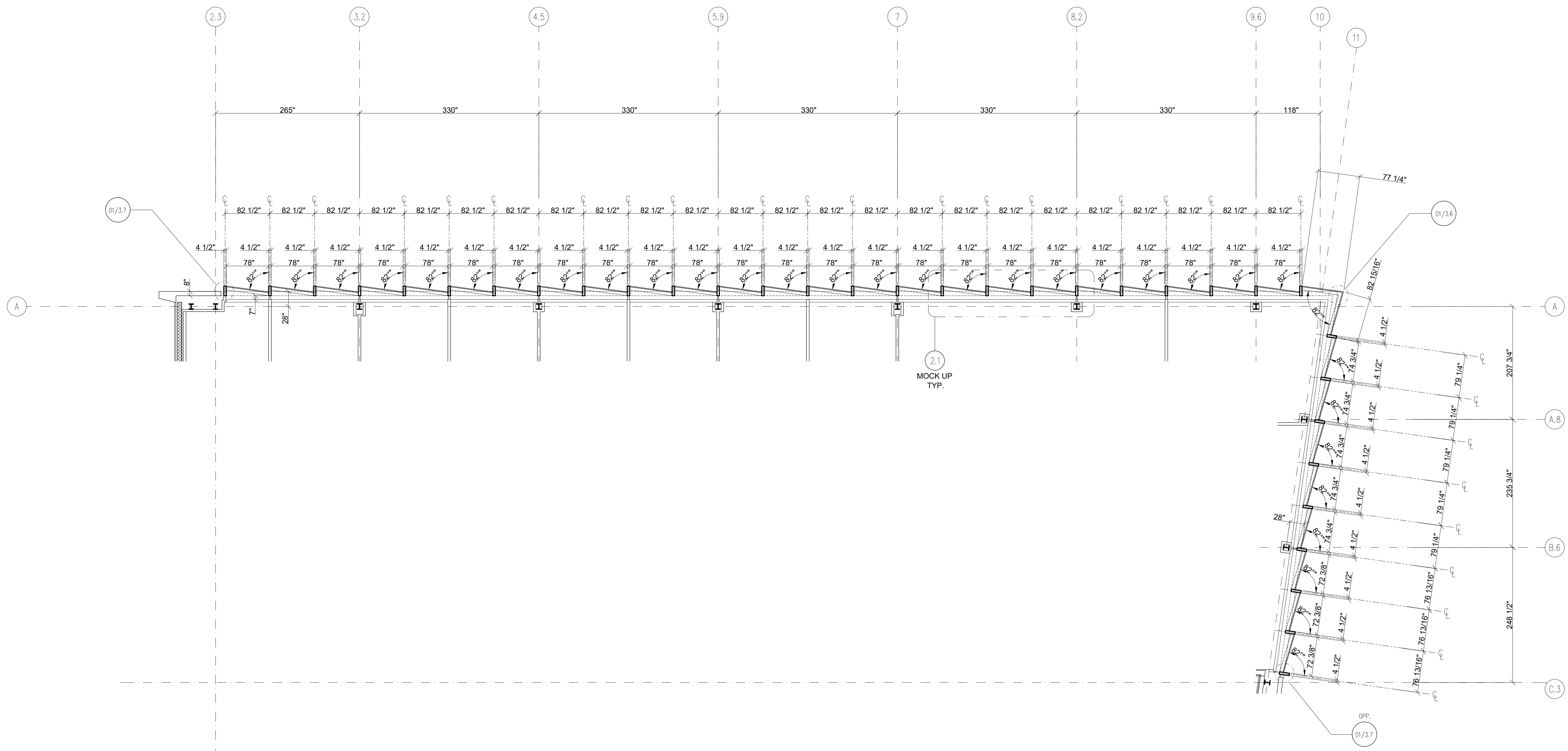
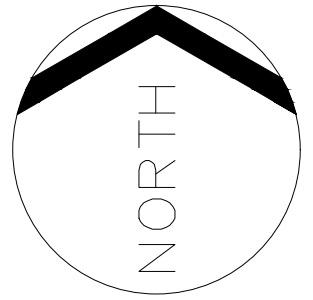

SECOND FLOOR LAYOUT

GENERAL NOTES
* ALL DIMENSIONS TO BE VERIFIED IN FIELD
* ALL ELEVATIONS ARE VIEWED FROM OUTSIDE OR FROM THE PULL SIDE OF THE DOOR
* ALL PARTS NO.(S) TO BE VERIFIED BY THE PURCHASING DEPARTMENT

REVISIONS
FIRST ISSUE: 05/25/2012
REVISION # 1 - DESIGN CONCEPT 07/16/2012
REVISION # 2 - DESIGN CONCEPT / DIES 08/10/2012
REVISION # 3 - FINAL DESIGN 09/04/2012
REVISION # 4 - CORRECTIONS FOR RECORD 10/29/2012

PROJECT:	G.G. BROWN LABORATORY MECHANICAL ENGINEERING ADDITION
PROJECT NO:	08143-3000
LAST UPDATE:	02/02/12
ARCHITECT:	Integrated Design Solutions
G.C.:	DeMARIA BUILDING COMPANY

SABCAD, INC.
PROFESSIONAL DRAWINGS

P.O. BOX 336
CLAWSON, MI 48017
PH: (248) 635-9155 FAX: (248) 282-0595
www.sabcadinc.com

SHEET DESCRIPTION
KEY PLAN
SABCAD JOB NO.12-25

SCALE: 1/8" = 1'-0"
SHEET NO.
1.2

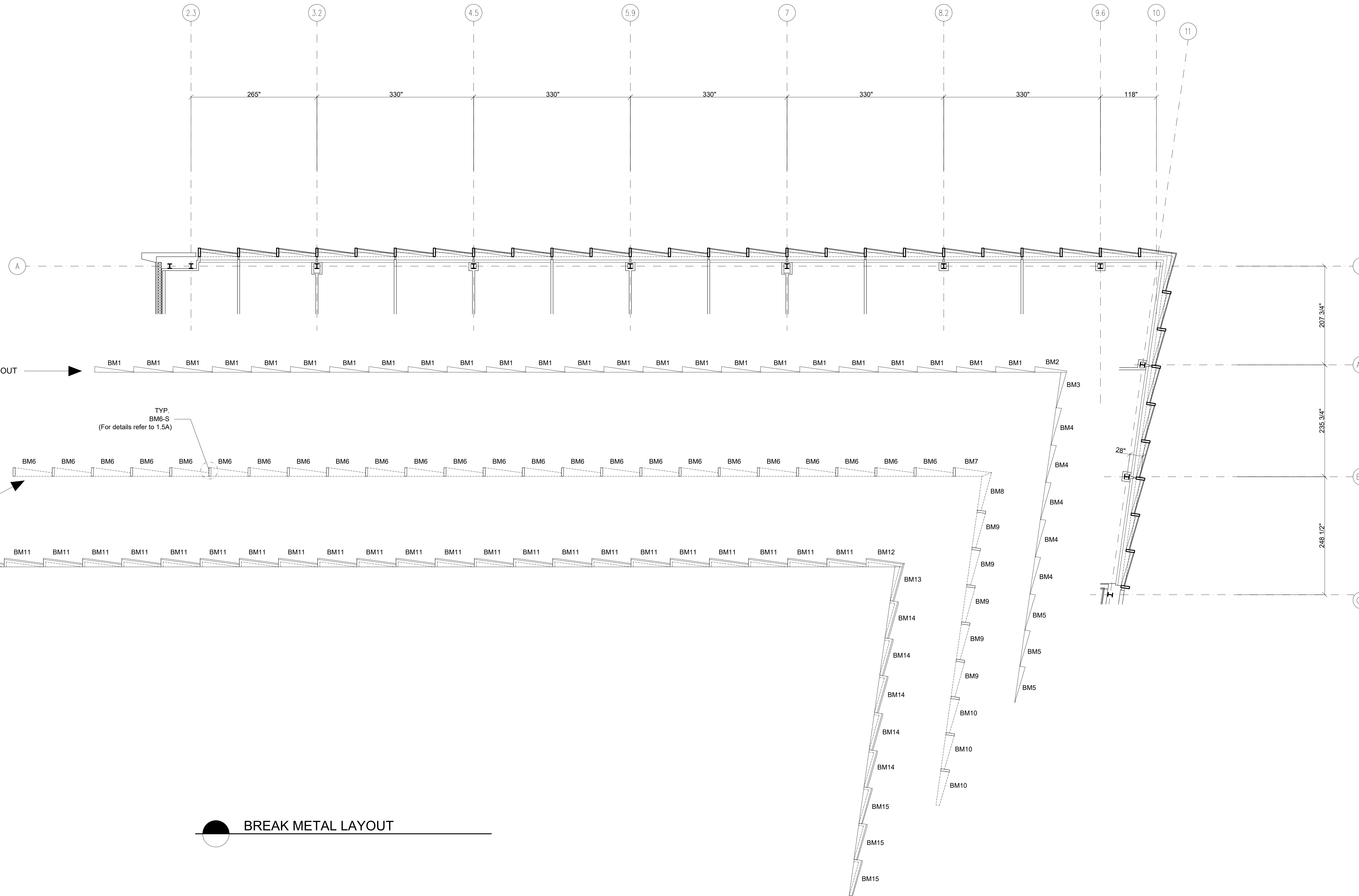
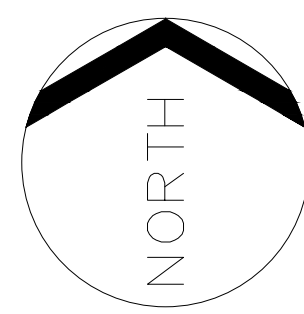

 **BREAK METAL LAYOUT**

GENERAL NOTES
* ALL DIMENSIONS TO BE VERIFIED IN FIELD
* ALL ELEVATIONS ARE VIEWED FROM OUTSIDE OR FROM THE PULL SIDE OF THE DOOR
* ALL PARTS NO.(S) TO BE VERIFIED BY THE PURCHASING DEPARTMENT

REVISIONS
FIRST ISSUE: 05/25/2012
REVISION # 1 - DESIGN CONCEPT 07/16/2012
REVISION # 2 - DESIGN CONCEPT / DIES 08/10/2012
REVISION # 3 - FINAL DESIGN 09/04/2012
REVISION # 4 - CORRECTIONS FOR RECORD 10/29/2012

PROJECT:	G.G. BROWN LABORATORY MECHANICAL ENGINEERING ADDITION
PROJECT NO:	08143-3000
LAST UPDATE:	02/02/12
ARCHITECT:	Integrated Design Solutions
G.C.:	DeMARIA BUILDING COMPANY



SABCAD, INC.
PROFESSIONAL DRAWINGS

P.O. BOX 336
CLAWSON, MI 48017
PH: (248) 635-9155 FAX: (248) 282-0595
www.sabcadinc.com

SHEET DESCRIPTION
BRAKE METAL LAYOUT
SABCAD JOB NO.12-25

SCALE: 1/8" = 1'-0"
SHEET NO.
1.4

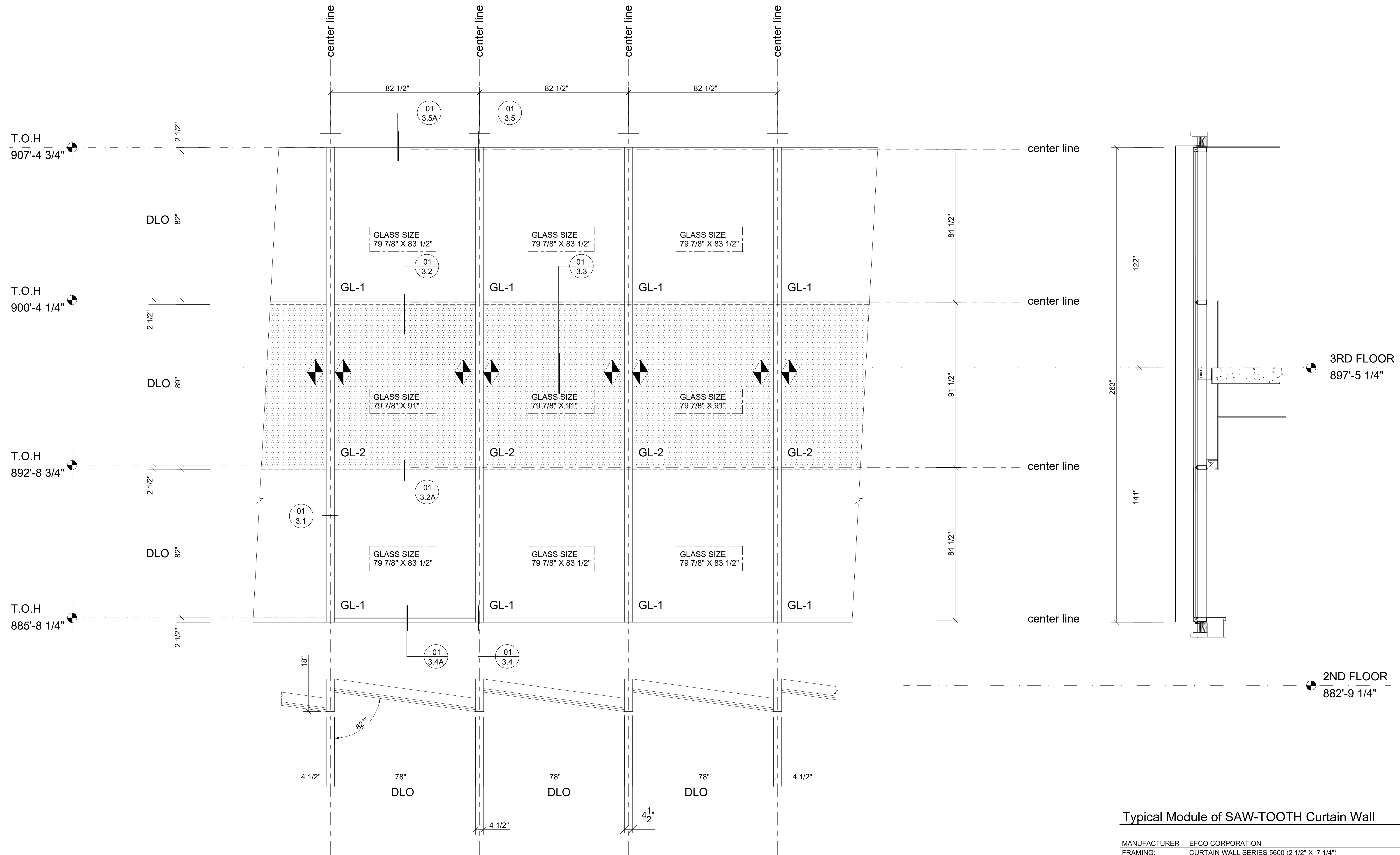

Typical Module of SAW-TOOTH Curtain Wall

MANUFACTURER	EFCO CORPORATION
FRAMING:	CURTAIN WALL SERIES 5600 (2 1/2" X 7 1/4")

GENERAL NOTES
* ALL DIMENSIONS TO BE VERIFIED IN FIELD
* ALL ELEVATIONS ARE VIEWED FROM OUTSIDE OR FROM THE PULL SIDE OF THE DOOR
* ALL PARTS NO.(S) TO BE VERIFIED BY THE PURCHASING DEPARTMENT

REVISIONS
FIRST ISSUE: 05/25/2012
REVISION # 1 - DESIGN CONCEPT 07/16/2012
REVISION # 2 - DESIGN CONCEPT / DIES 08/10/2012
REVISION # 3 - FINAL DESIGN 09/04/2012
REVISION # 4 - CORRECTIONS FOR RECORD 10/29/2012

PROJECT:	G.G. BROWN LABORATORY MECHANICAL ENGINEERING ADDITION
PROJECT NO:	08143-3000
LAST UPDATE:	02/02/12
ARCHITECT:	Integrated Design Solutions
G.C.:	DeMARIA BUILDING COMPANY

SABCAD, INC.
 PROFESSIONAL DRAWINGS
 P.O BOX 336
 CLAWSON, MI 48017
 PH: (248) 635-9155 FAX: (248) 282-0595
 www.sabcadinc.com

SHEET DESCRIPTION
ELEVATIONS
SABCAD JOB NO.12-25

SCALE: 1/2" = 1'-0"
SHEET NO. 2.1

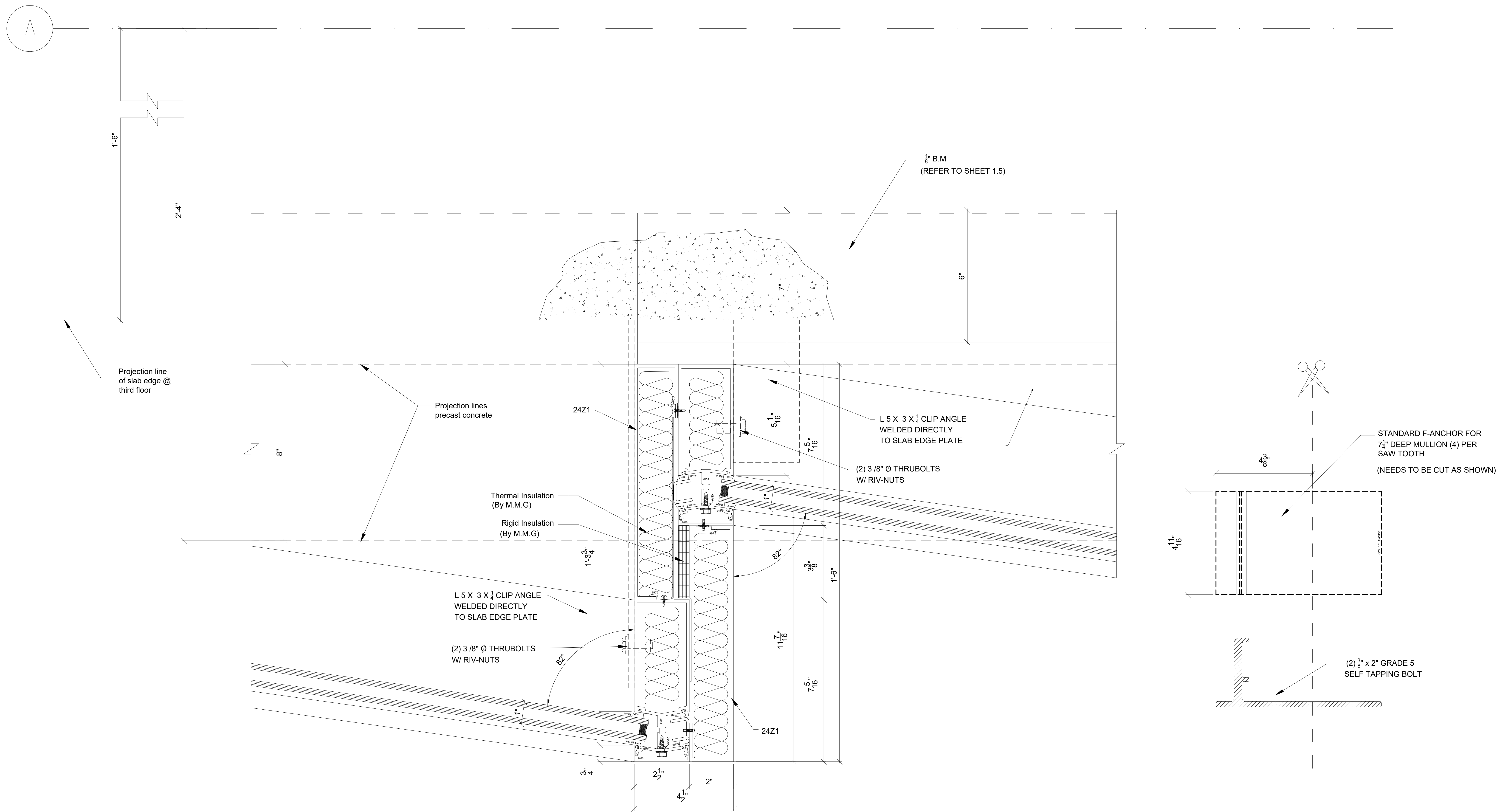

DETAIL 01 / 3.1
HORZ. CUT

GENERAL NOTES
* ALL DIMENSIONS TO BE VERIFIED IN FIELD
* ALL ELEVATIONS ARE VIEWED FROM OUTSIDE OR FROM THE PULL SIDE OF THE DOOR
* ALL PARTS NO.(S) TO BE VERIFIED BY THE PURCHASING DEPARTMENT

REVISIONS	
FIRST ISSUE:	05/25/2012
REVISION # 1 - DESIGN CONCEPT	07/16/2012
REVISION # 2 - DESIGN CONCEPT / DIES	08/10/2012
REVISION # 3 - FINAL DESIGN	09/04/2012
REVISION # 4 - CORRECTIONS FOR RECORD	10/29/2012

PROJECT:	G.G. BROWN LABORATORY MECHANICAL ENGINEERING ADDITION
PROJECT NO:	08143-3000
LAST UPDATE:	02/02/12
ARCHITECT:	Integrated Design Solutions
G.C.:	DeMARIA BUILDING COMPANY

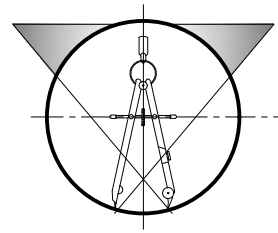

SABCAD, INC.
 PROFESSIONAL DRAWINGS

P.O BOX 336
 CLAWSON, MI 48017
 PH: (248) 635-9155 FAX: (248) 282-0595
 www.sabcadinc.com

--

SHEET DESCRIPTION
DETAILS
SABCAD JOB NO.12-25

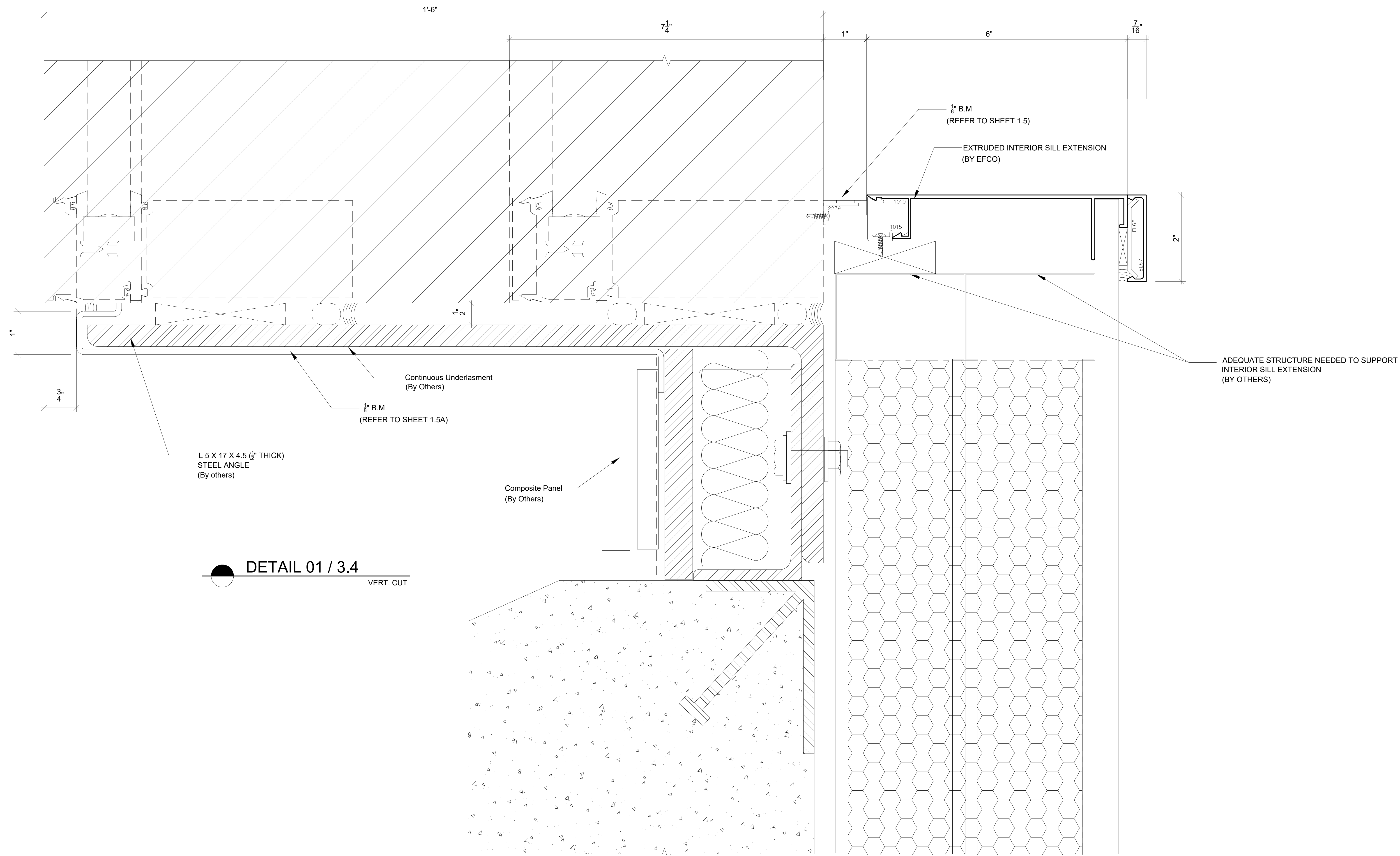
SCALE 1 : 2
SHEET NO.
3.1



DETAIL 01 / 3.4
VERT. CUT

GENERAL NOTES
* ALL DIMENSIONS TO BE VERIFIED IN FIELD
* ALL ELEVATIONS ARE VIEWED FROM OUTSIDE OR FROM THE PULL SIDE OF THE DOOR
* ALL PARTS NO.(S) TO BE VERIFIED BY THE PURCHASING DEPARTMENT

REVISIONS	
FIRST ISSUE:	05/25/2012
REVISION # 1 - DESIGN CONCEPT	07/16/2012
REVISION # 2 - DESIGN CONCEPT / DIES	08/10/2012
REVISION # 3 - FINAL DESIGN	09/04/2012
REVISION # 4 - CORRECTIONS FOR RECORD	10/29/2012

PROJECT:	G.G. BROWN LABORATORY MECHANICAL ENGINEERING ADDITION
PROJECT NO:	08143-3000
LAST UPDATE:	02/02/12
ARCHITECT:	Integrated Design Solutions
G.C.:	DeMARIA BUILDING COMPANY

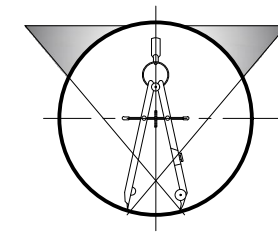

SABCAD, INC.
PROFESSIONAL DRAWINGS
P.O. BOX 336
CLAWSON, MI 48017
PH: (248) 635-9155 FAX: (248) 282-0595
www.sabcadinc.com

SHEET DESCRIPTION
DETAILS
SABCAD JOB NO.12-25

SCALE : FULL
SHEET NO. 3.4

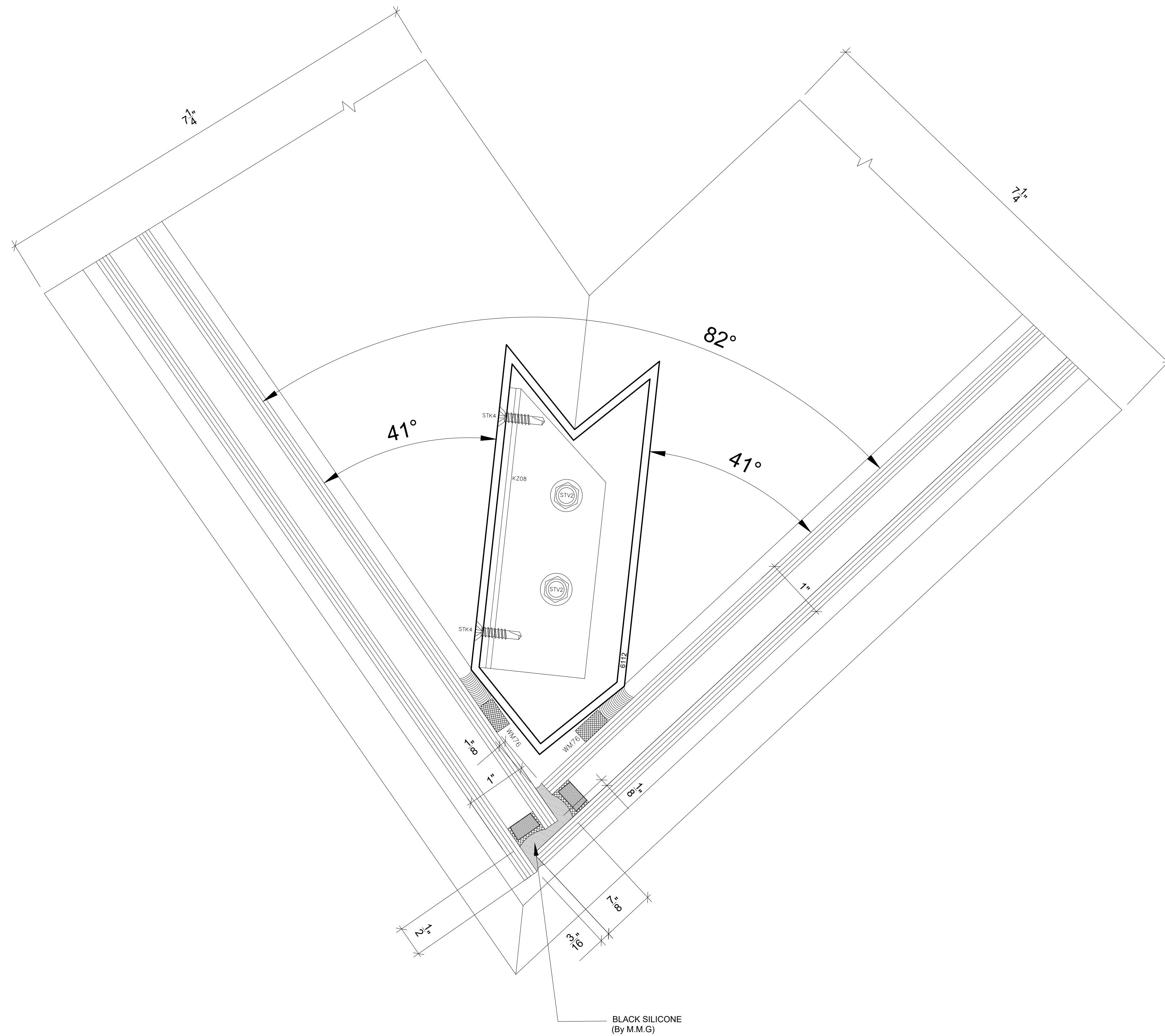

 **DETAIL 01 / 3.6**
HORZ. CUT

GENERAL NOTES
* ALL DIMENSIONS TO BE VERIFIED IN FIELD
* ALL ELEVATIONS ARE VIEWED FROM OUTSIDE OR FROM THE PULL SIDE OF THE DOOR
* ALL PARTS NO.(S) TO BE VERIFIED BY THE PURCHASING DEPARTMENT

REVISIONS
FIRST ISSUE: 05/25/2012
REVISION # 1 - DESIGN CONCEPT 07/16/2012
REVISION # 2 - DESIGN CONCEPT / DIES 08/10/2012
REVISION # 3 - FINAL DESIGN 09/04/2012
REVISION # 4 - CORRECTIONS FOR RECORD 10/29/2012

PROJECT:	G.G. BROWN LABORATORY MECHANICAL ENGINEERING ADDITION
PROJECT NO:	08143-3000
LAST UPDATE:	02/02/12
ARCHITECT:	Integrated Design Solutions
G.C.:	DeMARIA BUILDING COMPANY



SABCAD, INC.
PROFESSIONAL DRAWINGS

P.O. BOX 336
CLAWSON, MI 48017
PH: (248) 635-0155 FAX: (248) 282-0595
www.sabcadinc.com

SHEET DESCRIPTION
DETAILS
SABCAD JOB NO.12-25

SCALE : FULL
SHEET NO. 3.6

A

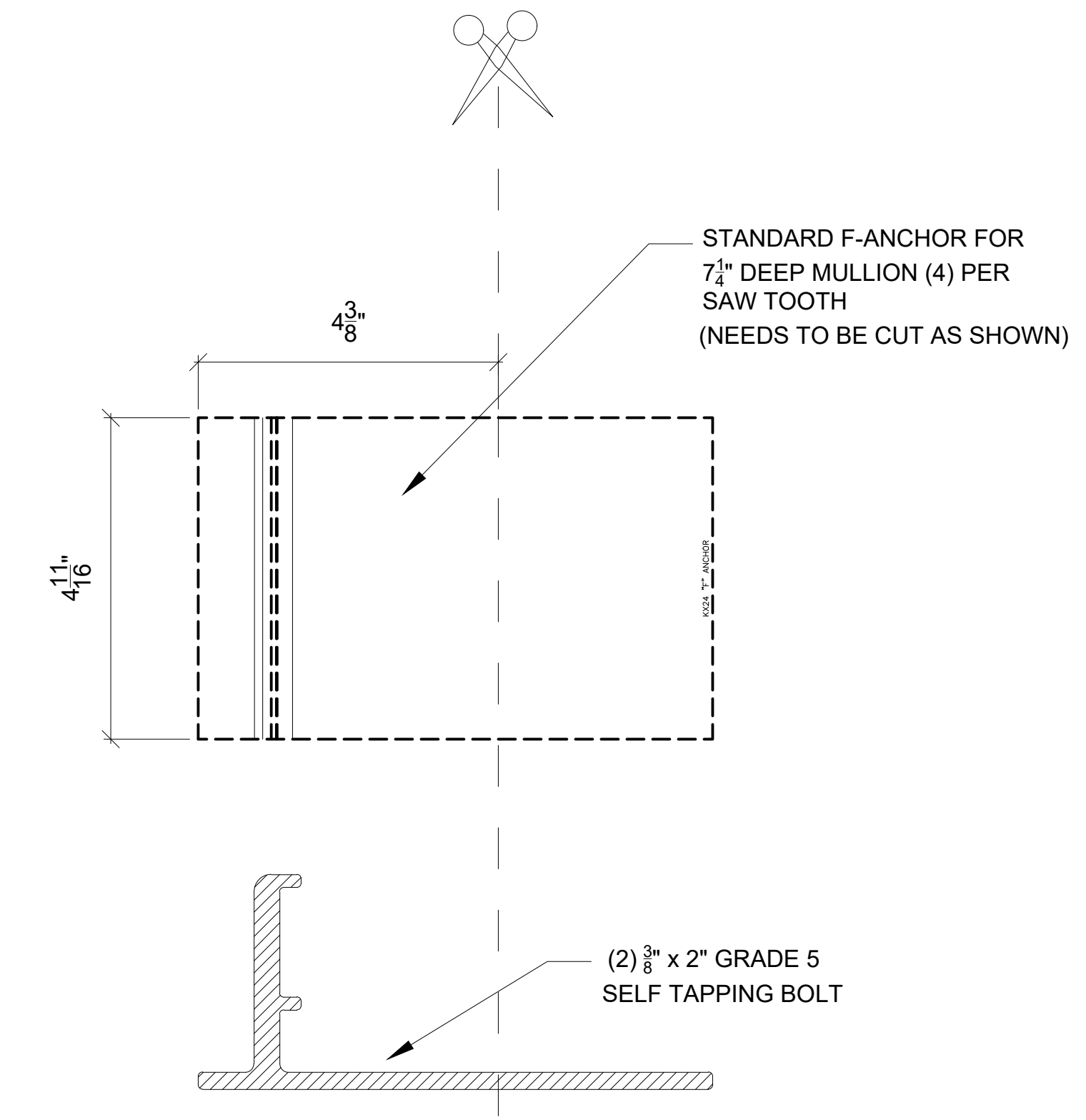
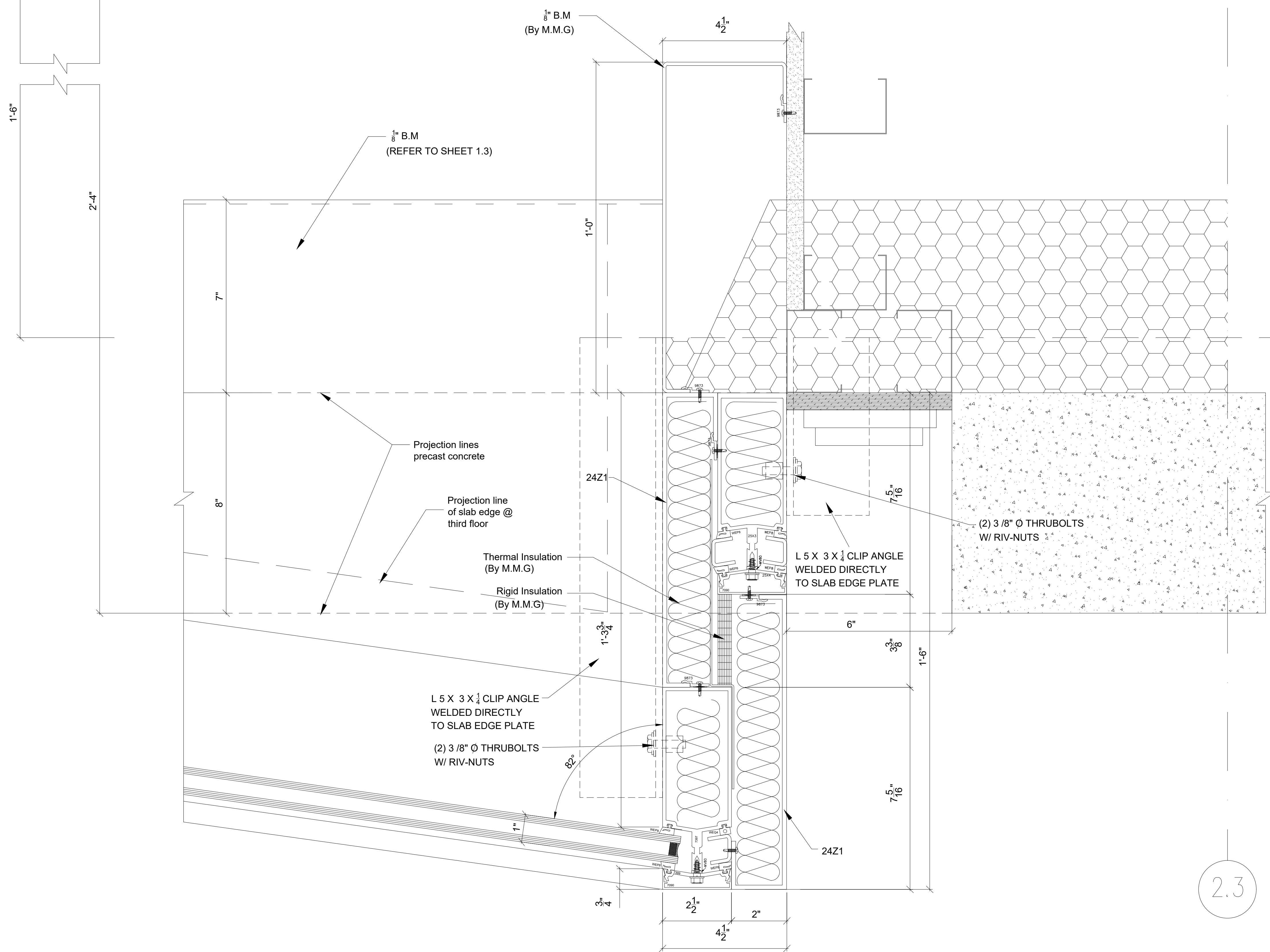

2.3

DETAIL 01 / 3.7
HORZ. CUT

GENERAL NOTES
* ALL DIMENSIONS TO BE VERIFIED IN FIELD
* ALL ELEVATIONS ARE VIEWED FROM OUTSIDE OR FROM THE PULL SIDE OF THE DOOR
* ALL PARTS NO.(S) TO BE VERIFIED BY THE PURCHASING DEPARTMENT

REVISIONS
FIRST ISSUE: 05/25/2012
REVISION # 1 - DESIGN CONCEPT 07/16/2012
REVISION # 2 - DESIGN CONCEPT / DIES 08/10/2012
REVISION # 3 - FINAL DESIGN 09/04/2012
REVISION # 4 - CORRECTIONS FOR RECORD 10/29/2012

PROJECT:	G.G. BROWN LABORATORY MECHANICAL ENGINEERING ADDITION
PROJECT NO:	08143-3000
LAST UPDATE:	02/02/12
ARCHITECT:	Integrated Design Solutions
G.C.:	DeMARIA BUILDING COMPANY

SABCAD, INC.
PROFESSIONAL DRAWINGS

P.O. BOX 336
CLAWSON, MI 48017
PH: (248) 635-9155 FAX: (248) 282-0595
www.sabcadinc.com

SHEET DESCRIPTION
DETAILS
SABCAD JOB NO.12-25

SCALE 1 : 2
SHEET NO. 3.7